

LED Underwater Lighting System

User Guide



Model Number: LT6250LED-LUX

Date of purchase: _____

www.diverite.com

DEVELOPED BY

Dive Rite
175 NW Washington Street
Lake City, FL 32055
Phone: 386.752.1087
Fax: 386.755.0613
Web: www.DiveRite.com

COPYRIGHT NOTICE

Copyright © 2009 Lamartek, Inc. dba Dive Rite

This manual is copyrighted by Lamartek, Inc. dba Dive Rite. You may not reproduce, translate, transcribe, or transmit any part of this manual without express, written permission from Lamartek, Inc. dba Dive Rite.

LIMITED WARRANTY

Lamartek, Inc. dba Dive Rite will — at its sole discretion — repair or replace dive light components proved to be damaged by faulty manufacture or material, at no cost, for a period of up to one year (365 days) from the date of purchase.

ALL WARRANTY CLAIMS MUST BE RETURNED TO THE STORE WHERE PURCHASED OR DIRECTLY TO DIVE RITE. A COPY OF THE PURCHASE RECEIPT MUST BE INCLUDED WITH THE PRODUCT.

- Canister bodies and the metal portions of light heads are warranted for the life of the product.
- Batteries are warranted against defects in manufacture or material for of up to one year (365 days) from date of purchase. This warranty does not cover loss of battery “burn time” — condition that results almost exclusively from mis-use or abuse. Users must read and study the rated “burn time” information appearing Dive Rite’s website. Failure to do so can easily result in expensive damage not covered under warranty.
- Attempting to charge damaged batteries can further result in damage to chargers. This is not covered under warranty — nor is damage to chargers caused by nonstandard alternating current voltages or cycle rates. Chargers returned under warranty must be accompanied by the battery they were being used to charge. If the battery is determined to be the cause of charger damage, no warranty coverage will be provided.
- The warranty also specifically excludes bulbs, lenses, fuses, O-rings, or other conditions **resulting from misuse, negligence, failure to properly lubricate o-rings, alteration, accident, or unauthorized repair.**
- This warranty applies only to the original retail purchaser. It does not cover commercial or rental use, nor does it extend to units purchased from other than an authorized Dive Rite dealer.
- To make a claim under this warranty, the owner must have registered his/her warranty using Dive Rite’s website (www.diverite.com). All warranty repairs (international or domestic) *must* be accompanied by a copy of the purchase receipt. For warranty repairs (international or domestic) the product must be returned to the *store* where the item was purchased or directly to Dive Rite. A Return Authorization must be obtained by calling Dive Rite corporate offices (386-752-1087) to send items to Dive Rite. No warranty service will be performed for other than registered owners.

Note: *Local dealers and distributors are not responsible for service of items purchased from unauthorized dealers, internet dealers, or dealers from other territories.*

- This warranty becomes void if dive light components are damaged by anything other than normal recreational diving use, or if they have been serviced or repaired by other than authorized Dive Rite dealers.
- Repairs made under this warranty will not extend the warranty period.
- All further claims, especially for damage after diving accidents, are excluded from coverage under this warranty.
- Lamartek, Inc., dba Dive Rite, has no obligation to honor any extension of this warranty.

All Dive Rite light systems are pressure and burn tested at the factory prior to delivery. When light systems are returned to Dive Rite for warranty service, the first thing we do is assemble the light precisely as outlined in this manual, including proper lubrication and installation of o-rings. We then pressure test the light, just as we did when it was new. If the light passes this second pressure test, we have to assume that any reported flooding must have resulted from failure to properly assemble and/or maintain the light as outlined in this manual — in which case no warranty coverage is provided.



www.DiveRite.com

LT6250LED-LUX LED Light

Product Description



The LED-LUX light head is a compact LED light head designed for underwater use. The light head features an attachment point for a clip so it can be clipped to a BC or harness. The LED light head is rated to 1000 lumens per square meter as measured at a distance of 10 feet. This light head comes standard with an elastic hand mount.

Specifications

Lens: Flat glass port

Bulb: 3 LED (Light Emitting Diodes) Array

Color temperature: 6,500 degrees Kelvin

Light Output: to 1000 lumens per sq meter at 10 feet

Bulb life: 10 to 15 years if used underwater with water temperatures no warmer than 75 degrees Fahrenheit

Hand mount: Elastic (standard)

Size

Length: 4 in. (10.16 cm)

Diameter: 2 in. (5.08 cm)

Cautions

- The light is designed for underwater use. Water provides cooling. Running the light out of the water can cause the light head to get extremely hot. Avoid looking directly at the bulb. The LED output at the lens is extremely bright and may cause eye damage.
- Turn the light off if it dims significantly or risk permanent battery damage.
- Disconnect the light head from the battery pack when traveling. If the light accidentally turns on, the light head could overheat and cause damage to the light head or potentially cause a fire.

Post-Dive Care

- Inspect the light head for any leakage or other damage
- Rinse the light head thoroughly in fresh water and allow it to dry

Dealing With a Flooded Light Head

The risk of flooding or damaging a light head can be greatly reduced by following the procedures and information on this data sheet.

Determining if a light head is flooded can be as obvious as pouring water out of the lens after a dive or as subtle as noticing droplets of water inside the lens or corrosion on the bulb.

Note: If your light head floods, do not continue to use the light. Arrange with your dealer to return the light to Dive Rite for repair. Flooding damage cannot be fixed or corrected in the field.

Dealing with a flooded light head:

1. Turn the light off. The longer current flows, the more damage can take place.
2. Disconnect and remove the battery from the canister.
3. Pour out any water in the canister.
4. Return all affected parts back to Dive Rite for repair.



www.DiveRite.com

LT6324 and LT6026 NiMH Battery Pack and Charger

Product Description



The LT6324 NiMH Battery Pack is used with the Slimline light canister and can power an HID or LED light head. The battery provides 5 hours of burn time. The battery pack is maintenance free, and does not develop a memory.

The LT6026 charger connects to any standard power outlet and is responsible for charging the battery. It connects directly to the wiring harness plug on the battery pack and then plugs into any standard wall outlet.

Specifications

Battery pack

Rating: 12 V, 4500 mA NiMH

Burn time: 5 hours

See Note below

Plug: Standard 2-pole trailer plug

Note: To obtain maximum burn times, the batteries must be cycled 4 to 6 times before the cells are at peak performance. During the first few charge and discharge cycles, burn times may not reach the full rate.

Charger

Rating: 120/220 VAC, auto sensing

Indicators: Red and green LED

Plugs: Standard 2-pole trailer plug and a standard 2-pronged wall outlet plug

Cautions

1. Always connect the battery and charger before plugging the charger into the wall socket. Always unplug the charger from the wall socket before disconnecting the charger from the battery.
2. Failure to disconnect the battery and charger before leaving them unattended for extended periods of time may cause damage to the items and increase the risk of fire and explosion.

Charging the Battery

Before using your light, make sure the battery is fully charged.

Battery charging notes:

- The battery may not attain full burn time until you have charged and discharged the battery several times. The battery may need to be cycled (charged and discharged) three to five times before maximum burn times are reached.
- Flickering of the light before maximum burn time is reached is an indication that the battery has either not been fully charged or that the battery has not been charged and discharged enough times (see note above). If the light begins flickering, turn it off immediately and recharge the battery.

To charge the battery:

1. Remove the battery from the canister.
2. Connect the charger plug into the battery pack plug.

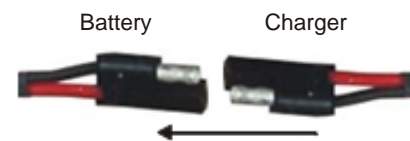

3. Plug the charger into a wall outlet.
4. Allow the battery to fully charge. The LED on the charger indicates when the battery is fully charged.

The red LED senses power. The green LED flashes three times to sense battery voltage, rapid flashes while charging the battery, and is on steady when the battery is fully charged.
5. Unplug the charger from the wall socket.
6. Disconnect the charger from the battery.

Maintaining the Battery

The battery is maintenance free. After each dive, you should fully re-charge the battery. It does not matter how much or how little you use the battery during a dive. The battery will not develop a memory of a particular dive time.

You should avoid fully discharging the battery (a condition known as deep discharge). To avoid battery damage due to deep discharge, follow the burn time specifications on this data sheet. Keep light usage within the time listed. This greatly extends battery life.

Note: Refer to Dive Rite's website for more information about making your battery last.



www.DiveRite.com

Slimline Light Canister

Product Description



The Slimline Light Canister is formed from a single piece of extruded poly-vinyl chloride pipe (PVC). The PVC material and round design make it extremely strong under extreme pressure. The canister is extremely small in diameter and ideal for a low profile dive system. The canister holds the battery pack that powers the light head. The canister lid contains the power cable that connects the light head to the batteries, an on/off power switch with protector, an o-ring seal, which keeps water from entering the canister, and compression style locking latches, which prevents accidental opening of the latches. The canister webbing loop is used to mount the canister to a BC or harness.

Specifications

Size

Height: 9 inches (22.86 cm)

Diameter: 2.6 inches (6.60 cm)

Weight: 3.8 pounds (1.72 kg) with battery

Buoyancy: Approximately 1.25 pounds (0.56 kg) negative in freshwater

Canister seal: single compression style o-ring

Canister locking: compression style locking latches

Mounting: 2-inch belt loop, webbing

Switch: Canister mounted toggle switch with switch protector

Battery size: 12 V, 4500 mA NiMH

Depth rating: 500 feet (152 m)

Inserting the Battery Pack

The battery pack sits vertically in the canister with the power cable extending from the top of the canister.

To insert the battery pack:

1. Align the bottom of the battery pack with the top of the canister. See the diagram below.
2. Slide the battery pack into the canister. Do not drop the battery into the canister.

User Product Data Sheet
Slimline - Light Canister

3. Orient the power cable so that it is not pinched or obstructed in any way.



Attaching the Canister Lid

The canister lid must be firmly attached to the canister using the locking latches on the side of the canister.

To attach the canister lid:

1. Inspect the o-ring for any dirt or grease and clean the o-ring if necessary with soap and water.
2. Plug the canister lid cable connector into the battery cable connector.

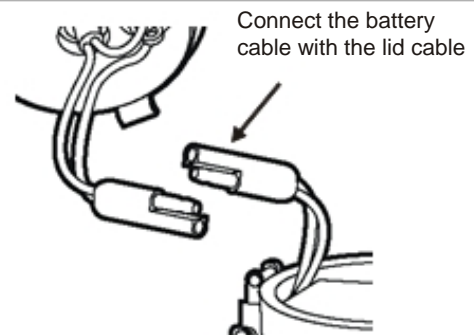

3. Tuck the connectors and wiring harness inside the canister.
4. Place the lid onto the top of the canister making sure the o-ring rests on the top of the canister and the lid latch attachments align with the locking latches.
5. Close and seal the lid using the locking latches. Close the latches simultaneously to evenly seal the o-ring.

v1.0
1 / 2

Mounting the Canister

The canister can be waist mounted on any standard BC harness, Transpac harness, or to the side of a dive tank.

Waist mounting the canister

The canister is equipped with a webbing loop for waist mounting the canister to a BC harness. You will need a standard cam-style buckle to waist mount your light.

To waist mount the canister:

1. Slide the BC or backpack waist harness through the webbing loop slot on the canister.
2. Position the canister on the waist harness on your hip so that it is comfortable and easy for you to access.
3. Slide the cam buckle onto the waist harness up to the light's webbing loop.
4. Cam the buckle in place. This keeps the canister from sliding on the waist harness.

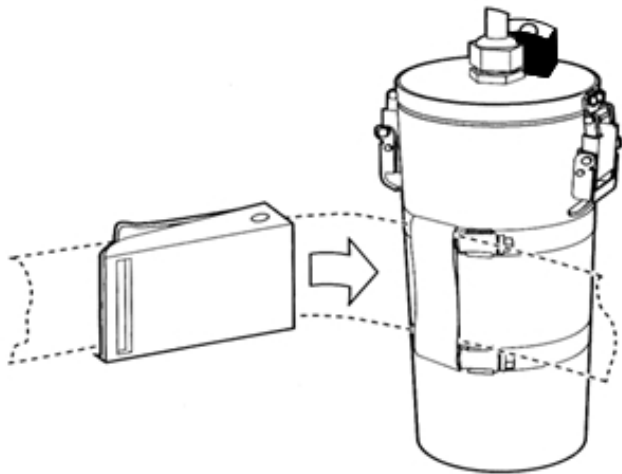

Tank mounting the canister

The webbing loop on the canister can be used to attach to a 2-inch (50 mm) tank BC cam strap. This is a good method for mounting a light to a single tank. If your tank cam strap is not suited for holding a heavy light, you can use a separate 2-inch cam strap (P/N 2032) to secure the light to the tank.

To tank mount the canister:

1. Position the canister so that the light cord is facing down, towards the bottom of the tank. This allows you to route the light cord next to your waist.
2. Place the canister on the right-hand side of the tank.
3. Slide the cam strap webbing through the canister webbing loop. Position the canister as close to your body as possible.
4. Wrap the cam strap around the tank and secure it using the cam strap buckle.

Transpac mounting the canister

You can attach the canister to the backside of a Transpac or Dive Rite backplate.

The canister is typically attached to the D-rings on the Transpac, or the holes in the backplate, with the Dive Rite AC3010 Canister Light Mounting Strap and Quicklinks. Your body size and the desired position of the canister and other gear will control what hardware you need and how you attach the hardware.

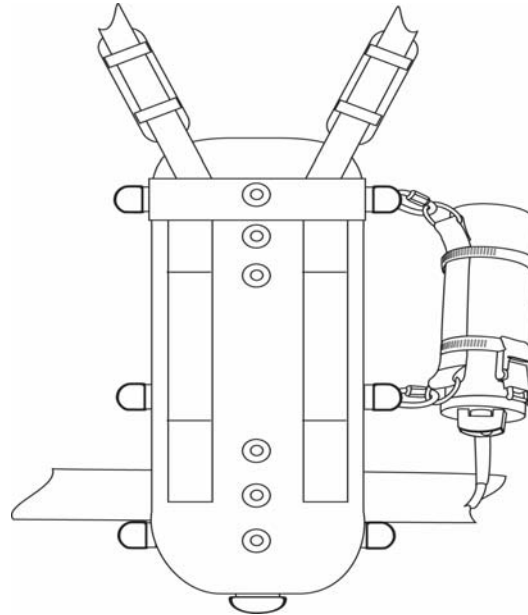

Dealing with a Flooded Canister

Minimizing the risk of flooding a canister can be greatly reduced by following the procedures and information on this data sheet.

Determining if a canister is flooded can be as obvious as pouring water out of the canister when you open the lid after a dive or as subtle as noticing water droplets inside the canister or corrosion on the battery terminals.

Note: If your canister floods, do not continue to use the light. Arrange with your dealer to return the light to Dive Rite for repair. Flooding damage cannot be fixed or corrected in the field.

Dealing with a flooded canister:

1. Turn the light off. The longer current flows, the more damage can take place.
2. Disconnect and remove the battery from the canister.
3. Pour out any water in the canister.
4. Rinse the canister inside and out with fresh water.
5. Towel dry all parts of the canister.
6. Return all affected parts to Dive Rite for repair.